

OMEN CENTER

Mk.I-B

[Mk.I Rev-B]

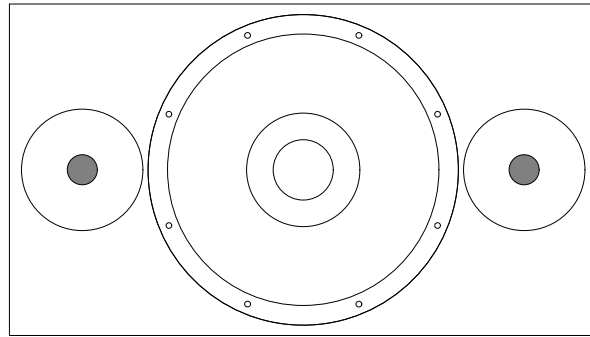

AD COPY + SPECIFICATIONS

8 | 2013



OMEN CENTER AD COPY + SPEC'S

ZU AUDIO OMEN CENTER Mk.I [REV-B] LOUDSPEAKER SYSTEM SPECIFICATIONS + INFORMATION

Omen Center Mk.I-B, what's different?

- New nanotech Zu260FRD/ND full-range driver.
- ClartiyCap MR capacitor used in the high-pass network.
- Revised high-pass network values for better transparency and driver blending.
- Much tighter matched pair tolerances on drivers and electrical components.
- 600 hours of high intensity factory burn-in.

Omen Center Mk.I-B is the same as the original with a few nice differences and one huge. Mark-one-bee is fitted with our nanotech sanctified composite paper cored cone. This new 10" full-range driver uses the same great Zu260 motor assembly, and when combined with these new nanometer materials and lay up gives the perfect combination of classic Zu tone and resolving transparency. The change in capacitors is also a pretty healthy step forward in treble resolution, switching from the PulseX to the ClartiyCap MR. And then the revision in the tweeter high-pass network for better transparency and blending of our Omen series nanotech full-range driver and ClartiyCap MR.

Omen Center is designed specifically for center-channel applications, with vocal resolution and natural presentation being the primary design goal. The Omen series represent the meat and potatoes of what Zu is about, standardized and designed for high-volume loudspeaker production—the only way to get this level of quality, performance, and good looks at this price. Our drivers, machine work, cabinetry, finish, assembly, packaging, all done by us in Ogden, Utah.

Even though Omen series are our entry level loudspeaker, they are still built to last a lifetime: cabinet material, adhesives, driver assemblies... every component is a high quality part designed to perform.

OMEN SERIES TECHNOLOGIES OLD & NEW

Omen Center, like all Zu products, is built around the critical human voice (A1, 55Hz, through A6 and all the possible harmonics, to approximately 10kHz). Serving this critical region of tone is Zu's 5th generation 260 standard motor 10.3" [260mm] nanotech/paper composite full-range driver. And despite what many audio snobs might think about it based on price, Omen loudspeakers are true state-of-the-art loudspeaker systems—two-channel stereo or multi-channel home theater.

FINISH

Standard finishes are top coated by UV protecting premium grade conversion varnish. All finish work is done in Zu's custom finish shop.



OMEN CENTER AD COPY + SPEC'S

ZU AUDIO OMEN CENTER Mk.I [REV-B] LOUDSPEAKER SYSTEM SPECIFICATIONS + INFORMATION

QUICK SETUP NOTES

Omen Center is designed to be used as a center-channel loudspeaker. The sound great mounted to a stand or sitting on a shelf.

The ideal position for Omen Center is horizontally in-line with the acoustic center of your left / right main loudspeakers—only really accomplished with acoustically transparent screens. When using it with direct view monitors, we recommend positioning it as close to the bottom of the screen as possible.

RoHS compliant. All parts used within Omen Center are 100% recyclable. They do not contain any toxic material as finished. Any Zu product or part may be sent back to Zu, free of charge, for proper reuse or disposal. Zu Omen Center loudspeaker systems are classified as a lifetime life-cycle product and will most likely be in service for well over 50 years.

TIPS ON GETTING GREAT SOUND FROM OMEN CENTER

Omen Center loudspeaker now get 600 hours of factory burn-in, it will sound good right out of the box but will not give you its best for several weeks, depending on how much play it get and what kind of music it sees. If at first you find it restrained and a bit conservative, relax, it will come around.

Zu Omen Center loudspeaker is sensitive to the cold. If you have received, moved or stored it in cold temperatures it will take a week or so to again sound its best.



OMEN CENTER AD COPY + SPEC'S

ZU AUDIO OMEN CENTER Mk.I [REV-B] LOUDSPEAKER SYSTEM SPECIFICATIONS + INFORMATION

Description	High efficiency, high output, direct radiating center-channel loudspeaker. Omen Center Mk.I-B features Zu's full-range snappy yet organic nanotech sanctified driver (260ND), no crossover or filters on full-range driver, complimented by twin composite dome time-aligned machined from billet tweeters to provide solid horizontal upper treble distribution and resolution (12kHz and up).
Architecture	Zu / orthogonal Scandinavian
Production	August 2013—
Dimensions H W D	11 x 19-1/2 x 8" [28 x 50 x 20.4cm]
Weight	31 pounds [14kg]
Packaged	one loudspeaker per shipping box, 36 pounds [16.5kg]
Bandwidth	50 – 25kHz
Efficiency	97dB SPL @ 1W, 1m
Impedance	12Ω, nominal full bandwidth
Horizontal Listening Window	50°
Vertical Listening Window	35°
Recommend Listening Distance	3 feet [1m] or more
Accepted Connectors	via standard 5-way binding posts: 1/4" spade [6.3mm], oversized 5/16" [8mm] spade, bare wire, banana plugs
Internal Cabling	Zu Mission hookup wire
Power Recommendations	4 – 12 watt (average room, moderate volume) 12 – 36 watt (large room, loud listening) 36 – 200 watt (large room, concert levels) 200 watt (maximum input power)
Amplification Considerations	anything that sounds good (floating load, any amp type or circuit is fine)
Tweeter Detail	2x Zu APT-L2 tweeter assembly (12k – 25kHz passband)
High-Pass Filter Detail	first order besseL @ 18kHz (12kHz acoustical) ClarityCap MR 1uF + loading R
Full-range Driver Detail	1x Zu260FRD/G4, 10-1/3" full-range driver, direct and unfiltered
Cabinet	North American Comp-60 composite high density fiberboard skinned with real wood veneer
Spike / Feet Insert Thread	none
Included With Loudspeaker	1x hard press-on full-range driver covers, installed 1x owner's manual
Life Expectancy	100 years; cabinet, and drivers, including the Zu 10.3" [260mm] drivers; even in direct sunlight
Manufacturers Country Of Origin	U.S.A. all parts and labor excluding just a few small parts
Compliances	RoHS WEEE
Warranty & Service	5 years limited on cabinet and drivers—warranty does not cover misuse, abuse, components upstream from the loudspeaker system, modifications or non-factory service.



OMEN CENTER AD CUSTOMER SPEC'S

ZU AUDIO OMEN CENTER Mk.I [REV-B] LOUDSPEAKER SYSTEM SPECIFICATIONS + INFORMATION

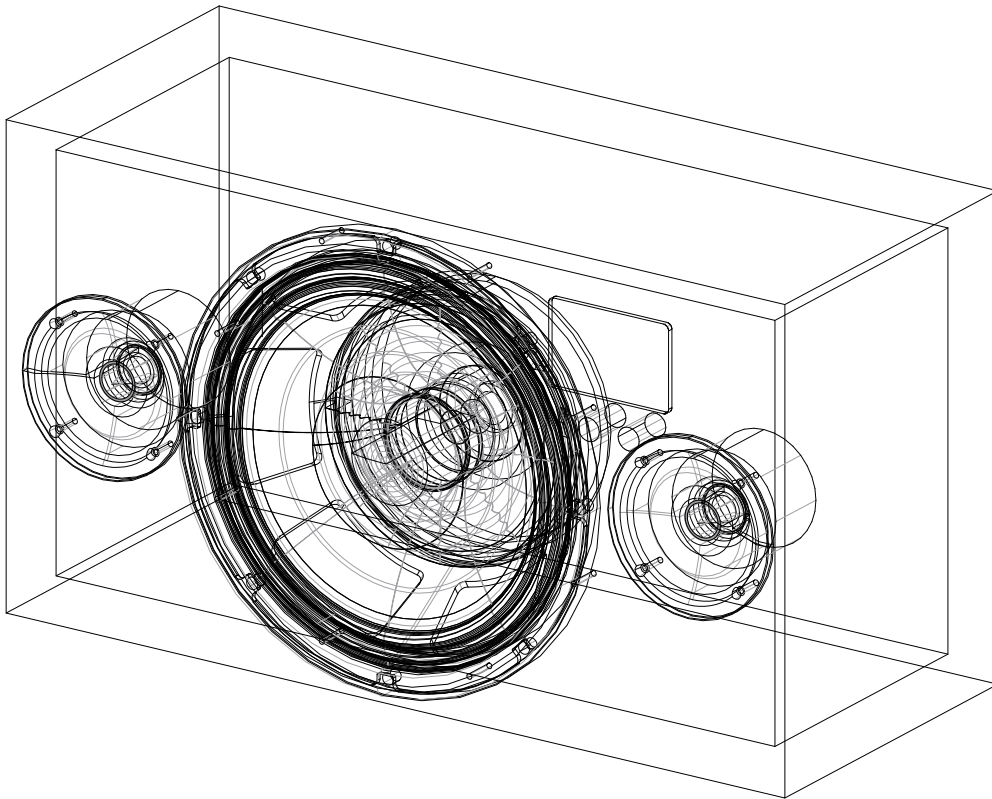



OMEN CENTER AD COPY + SPEC'S

ZU AUDIO OMEN CENTER Mk.I [REV-B] LOUDSPEAKER SYSTEM SPECIFICATIONS + INFORMATION

WARRANTY

Zu products are designed and manufactured to the highest quality. However, if something does go wrong Zu will fix or replace the product free of charge. Zu Omen Center loudspeakers have a five year limited warranty from date of purchase to original owner. If under normal home use you have any problems with drivers, cable, parts, cabinet, we will fix or replace the product. Loudspeaker warranty and service can usually be performed by the user, also known as DIY service, in such cases Zu will provide full technical support. This provides faster repair of product (reducing down time is always good), minimizes handling hassle and damage potential to both Zu and you, and reduces shipping costs.

Zu loudspeaker finish warranty covers color changes in paint, finish checking, and oxidizing. While we use the highest quality UV protecting topcoat finishes, we cannot guaranteed against fading and you should keep them out of direct sunlight, just like a piano. While every effort is made to ensure a perfect finish that will last a lifetime, this warranty does not cover damage from impact and abrasion, or seam / core construction visibilities in extreme high temperature / high humidity environments. Zu products are designed to be used in temperature and humidity controlled environments, namely your home or office unless otherwise stated. Warranty does not cover loudspeaker finish damage caused by the extremes of an uncontrolled environment.

If in the highly unlikely event that a Zu product arrives to you dead on arrival (D.O.A.), and after discussing it with a Zu tech, we will ship another of the same product at our expense and arrange for the D.O.A. product to be collected. If after inspection we find that you have misrepresented a returned product's condition, and that it was improperly handled or used, Zu will charge you for all damaged parts, labor, shipping and handling of the product.

Warranty does not apply to damage caused by operating the product outside the intended use, accident, another product, misuse, abuse, flood, fire, earthquake or any other external causes. Warranty does not cover damage caused by modification or service performed by anyone other than a Zu representative. Cosmetic damage is also excluded from warranty, as is all product that has any part of the Zu serial number removed.

When a product or part is exchanged the replacement becomes your property and the suspect or damaged part becomes Zu's property. Parts provided by Zu must be used in products for which the warranty service is claimed.

WHAT YOU CAN EXPECT IF WARRANTY SERVICE IS NEEDED

If warranty becomes necessary, you must call or email for a return of material authorization (R.M.A.) number, or to arrange for user serviceable parts. This provides opportunity to assist in diagnosing the problem and helps us to schedule for rapid turnaround in the event that parts, service or repair is needed. Upon factory inspection of parts or product, warranty eligibility will be determined. While service options, parts availability and response times will vary, we do our best to keep you happy. International customers should know that Zu will comply with all applicable export / import laws and regulations, you may be responsible for custom duties, taxes, broker fees, freight, and other charges. When shipping of product or part is required, repackage the complete product, or part, in its original packaging. If you have any questions about packaging please call or email. Product damage caused from incorrect repackaging is not eligible for refund or warranty and the freight company may also reject your insurance claim. Until we have the product back in the shop and sign-off that it is eligible, the product is still your property, we recommend you insure or declare the full value when shipping. We also recommend that you only ship with a freight company that has a good reputation and offers tracking and insurance for the full amount.